

Tube Amplifier Output Transformers

LL1620 , LL1623, LL1627

LL1620, LL1623 and LL1627 are output transformers for tube amplifiers, available with different core air-gaps for different types of output stages. The transformers are highly sectioned with harmonically sized sections, which results in a minimum leakage inductance. This, combined with a low capacitance coil winding technique results in a wide frequency range. The transformers have a special audio C-core of our own production. The transformers are unpotted, open frame type suitable for mounting inside an amplifier housing.

Physical dimensions, pin and mounting hole layout LL1620, LL1627 (all dimensions in mm)

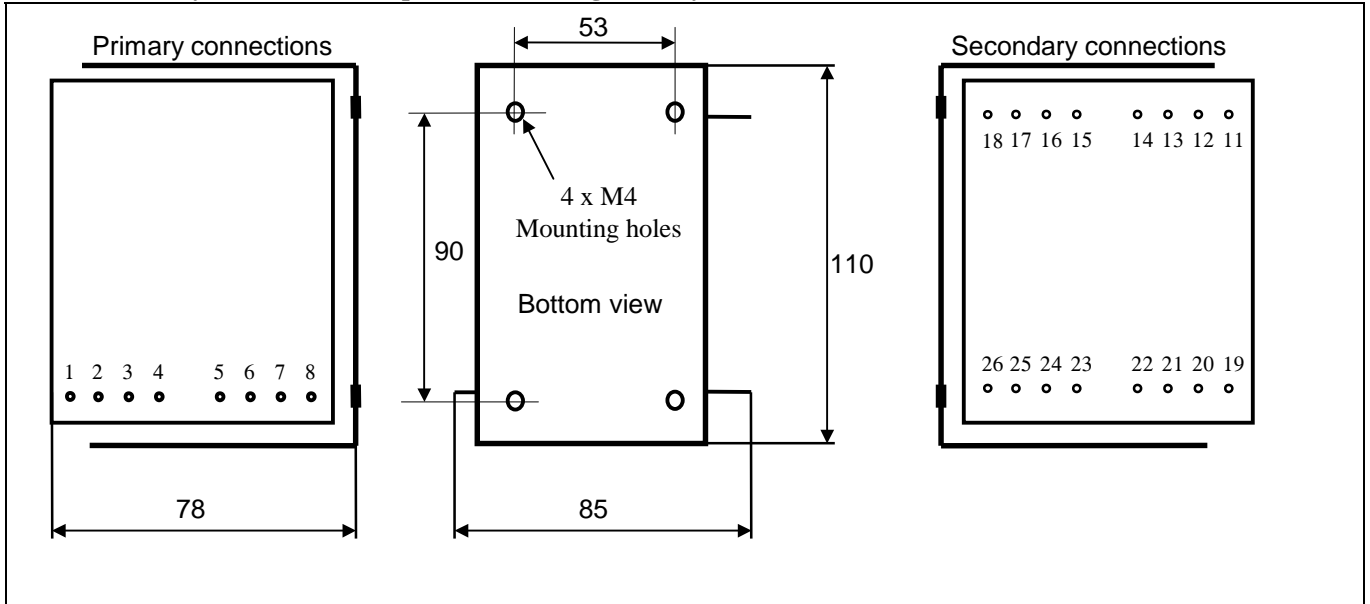

Physical dimensions, pin and mounting hole layout LL1623 (all dimensions in mm)

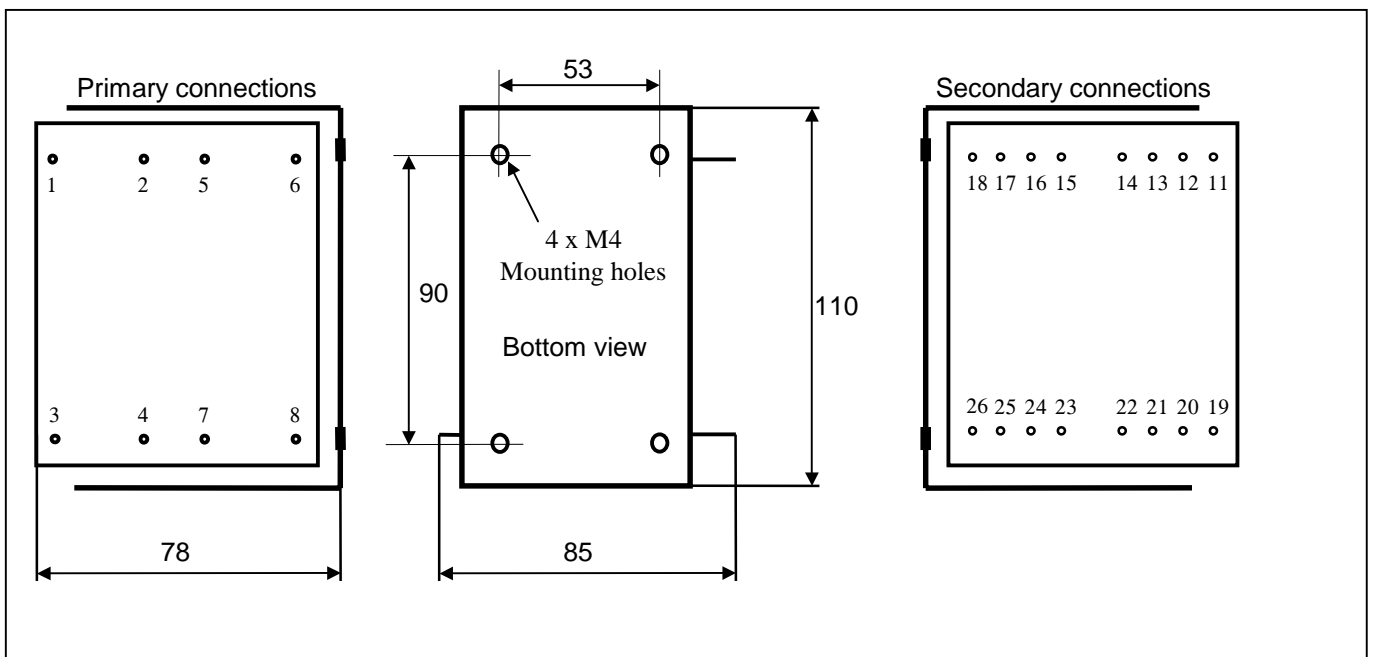

Pin spacing module:
Weight:

5.08 mm (0.2")
 2.5 kg

Winding schematics:

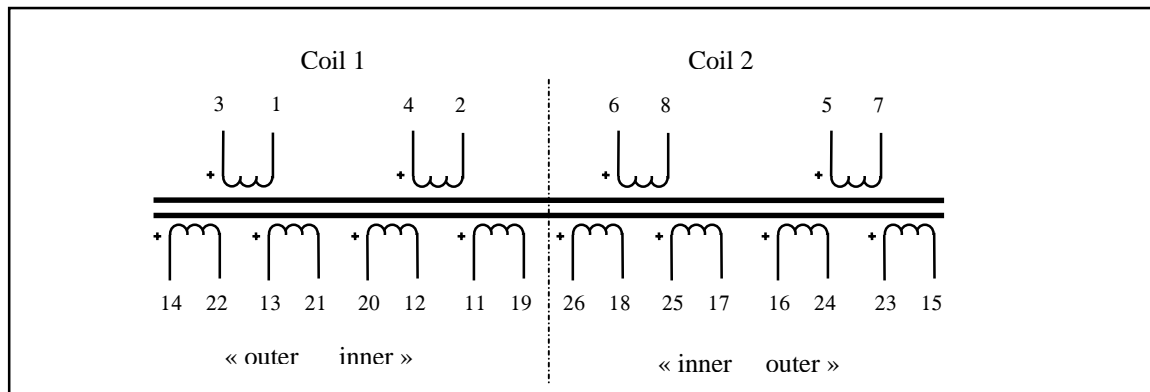

The inner windings have lower copper resistance due to smaller circumference

	LL1620		LL1623		LL1627	
Turns ratio:	4 x 19.2 : 8 x 1		4 x 13.4 : 8 x 1		4 x 8.5 : 8 x 1	
Static resistance of primary (all in series)	308 Ω (4 • 77 Ω)		164 Ω (4 • 41 Ω)		56Ω (4 • 14 Ω)	
Static resistance of each secondary (average)	0.4 Ω		0.4 Ω		0.4 Ω	
Primary leakage inductance (all in series)	13 mH		4.6 mH		1.9 mH	
Max. primary signal voltage r.m.s. at 30 Hz (all in series)	Push-Pull 860V	Single End 380V	Push-Pull 610V	Single End 270V	Push-Pull 380V	Single End 170V

Isolation between primary and secondary windings / between windings and core: 3 kV / 1.5 kV

Standard types:	LL1620 P-P	LL1620 / 40 mA	LL1620 / 60 mA	LL1620 / 80 mA
	LL1623 P-P	LL1623 / 60 mA	LL1623 / 90 mA	LL1623 / 120 mA
	LL1627 P-P	LL1627 / 90 mA	LL1627 / 140 mA	LL1627 / 185 mA

Frequency response: The frequency response is dependent on transformer type and connection alternative.
 E.g. for the LL1623 / 90 mA, connection alt. C, with $R_{SOURCE} = 650 \Omega$
 $R_{LOAD} = 8 \Omega$

you get:

Frequency response	7 Hz - 25 kHz	+/- 0.5 dB
Phase Shift	@ 20 Hz	2°
	@ 20 kHz	13.5°
Group delay ($\delta\phi/\delta\omega$)	@ 20 kHz	2.2 μs

Electrical characteristics

Primary Load Impedance, Primary DC Current Core Air-gap and Maximum Output Power

	Sec. connection for 4/8/16 Ω (See next page)			Core Airgap (Delta/2)			
	-/B/C	B/C/D	C/D/E	25 μ (Push-Pull)	125 μ (Single End)	190 μ (Single End)	250 μ (Single End)
	Primary Load Impedance			DC current for 0.9 Tesla (rec. operating point) Primary Inductance			
LL1627	2.3 kΩ	1.2 kΩ	0.65 kΩ	Push-Pull 60 H	90 mA 18 H	140 mA 12 H	185 mA 9 H
LL1623	5.6 kΩ	3.0 kΩ	1.6 kΩ	Push-Pull 150 H	60 mA 46 H	90 mA 30 H	120 mA 23 H
LL1620	11.5 kΩ	6.0 kΩ	3.3 kΩ	Push-Pull 300 H	40 mA 90 H	60 mA 60 H	80 mA 45 H
	Power and Loss						
All types	62W	125W	250W	Max. Power, P-P at 30 Hz			
	13W	25W	50W	Max. Power, S.E. at 30 Hz			
	0.2 dB	0.5 dB	0.8 dB	Loss across transformer			

Our recommendations on how to choose your tube output transformer

Push-pull output stages:

All our push-pull output transformers have a 25 microns core air gap to allow for a small DC unbalance of your output circuits.

Step 1 From your secondary load impedance (4, 8 or 16 ohms), we suggest a secondary connection alternative with 0.5 dB loss. This will give you a maximum power limit of 125W at 30 Hz, and a LF -1 dB point at 6.4 Hz for pentodes and lower still for triodes.

If you require more headroom at low frequencies, the 0.8 dB loss alternative expands the LF limit one octave.

Step 2 Your tube choice gives you a desired primary load impedance. Select the transformer type having a primary load impedance which best matches the desired impedance.

The LL1623 (5.6 kΩ plate-to-plate impedance) or the LL1620 (6.0 kΩ plate-to-plate impedance) suites many tubes like the 300B triode or the EL34 pentode. The 6C33 (low voltage, high current) requires a transformer LL1627 while high anode voltage tubes require the high impedance of the LL1620.

Footnote: In class A push-pull, each **tube** will see a load impedance = 1/2 transformer primary load impedance.
In class B push-pull, each **tube** will see 1/4.

Single-end output stages:

The core of Single End output transformers have an airgap. The purpose of the airgap is to accept the DC current of the output tube without saturating the core, leaving enough headroom for the sound signal. As a result of the airgap, the primary inductance is lower for SE output transformers compared to P-P dittos. In addition, the inductance tends to vary with DC current. For our high quality C- cores with carefully ground surfaces, the variation is within +7% of rated value.

Step 1 We recommend that, given your secondary load impedance (4, 8 or 16 ohms), you select a secondary connection alternative with 0.5 dB loss. This will give you a power limit of 25 W at 30 Hz. If you find that you require more bass headroom, select a secondary connection alternative with 0.8 dB loss.

Step 2 From the tube load line you determine a primary load impedance. This results in a choice of transformer main type.

Step 3 From the tube data sheet you also select your desired DC current. From the table above you select the transformer subtype (DC current) which best fits your needs. For many tubes such as the 300B and the EL34, the transformer LL1623 / 90 mA is the ideal choice.

Step 4 We define **Power Low Frequency Limit, F_{PL}** , as the frequency where $\omega L_p = R_{LOAD}$. (The reactive impedance of the transformer equals the primary load impedance). At F_{PL} , the output power is reduced to 50%. For the LL1623 / 90 mA in a 0.5 dB loss connection, $F_{PL} = 16$ Hz ($R_{PRIMARY} = 3.0$ kohms and $L_p = 30$ H).

Step 5 We define **Response Low Frequency Limit, F_{RL}** , as the frequency where a (small) output signal is reduced with -1 dB due to finite primary inductance. $F_{RL} = \omega / \pi$, if you solve ω in

$\omega L_p = (R_{LOAD} \text{ in parallel with } R_{ANODE})$.

For the LL1623 / 90 mA and a 300B triode, $F_{RL} = 7$ Hz. ($R_{ANODE} = 650$ ohms, $R_{PRIMARY} = 3.0$ kohms and $L_p = 30$ H),

Primary Connections

⊗ Indicates phase

LL1620, LL1627
Primary connection for push-pull output stage

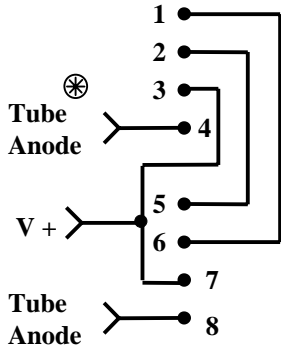

LL1620, LL1627
Primary connection for single-end output stage

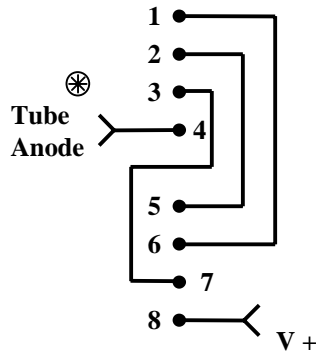

LL1623 Primary connection for push-pull output stage

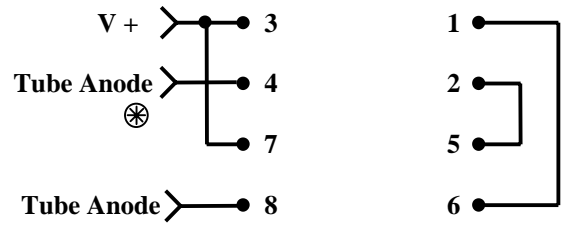

LL1623 Primary connection for single-end output stage

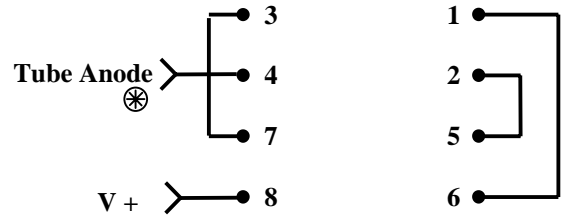

Secondary connections

⊗ Indicates phase

Max secondary Voltage RMS @ 30 Hz	
Push-Pull	Single End
Copper resistance	Windings in series

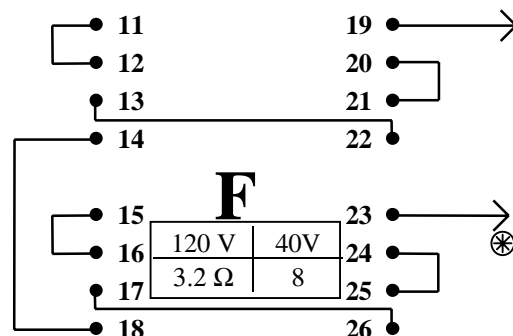
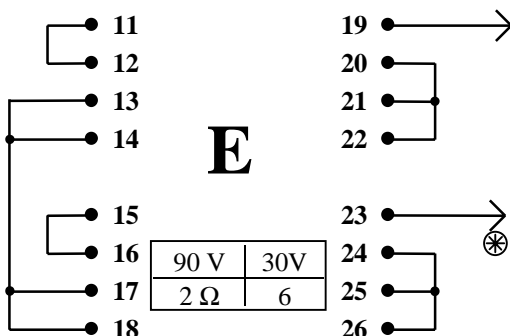
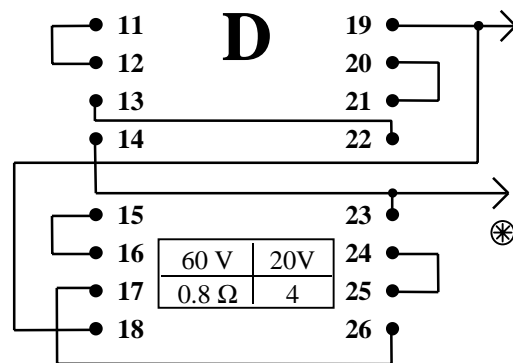
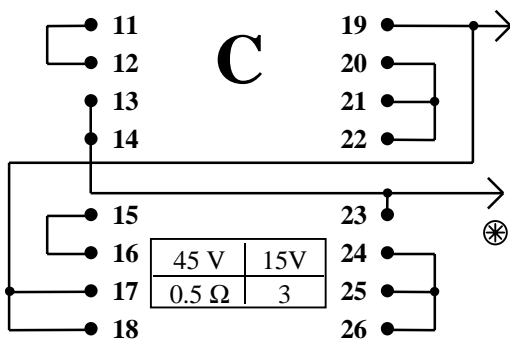
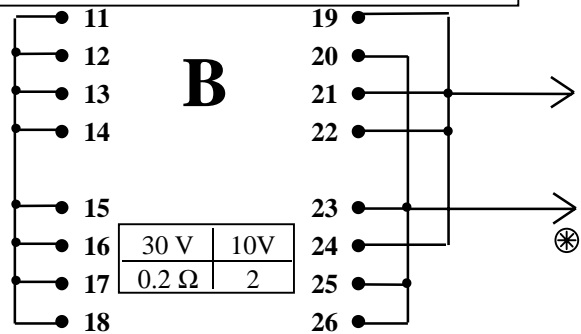
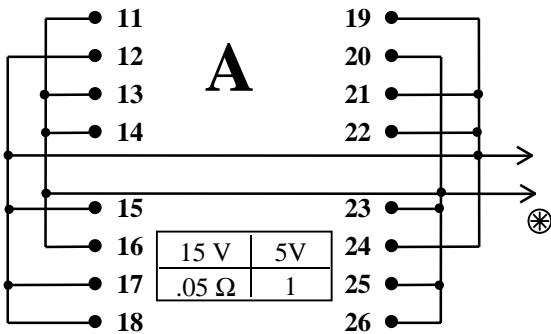

LL1620, LL1623, LL1627